

The Growco FBDF Series digital control valve is typically used together with batch controllers or PLC for loading of products used in trucks loading terminals, barge loading terminals, rail cars, or related processing installations.

➤ **FEATURES:**

- Stable and reliable operations.
- Changeable speed of opening and closing operations; avoid “water hammer”.
- Controlled automatically or manually.
- Installed horizontally or vertically.
- Simple structure and easy maintenance
- Optional Voltage : AC220V or DC24V



**Typical Photograph of FBDF Series**

➤ **DIMENSIONS (DIAPHRAGM TYPE VALVES)**

Spec. DN*	L (mm)	A (mm)	D (mm)	Net Weight (kg)
DN-40 (1.5")	200	130	160	20
DN-50 (2")	210	130	165	22
DN-80 (3")	280	155	200	35
DN-100 (4")	350	180	220	60
DN-150 (6")	430	220	280	85
DN-200 (8")	560	270	340	120

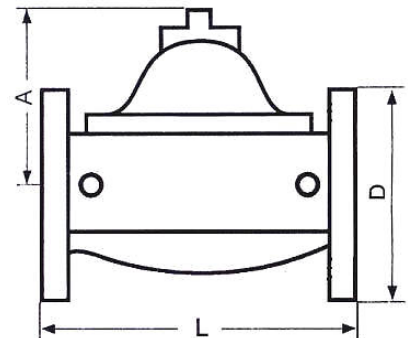

**Note:** DN\* - Nominal Diameter based flange connection. Consult us when necessary.

➤ **SPECIFICATIONS**

Item	Model	FBDF - Series
Working medium		Petroleum products such as diesel, gasoline & kerosene.
Maximum Viscosity		Up to 40cP / 40mPa-s. Consult us for higher viscosity.
Medium temperature		-25deg C ~ 65deg C. Consult us for higher temperature.
Working pressure (MPa)		0.02~1.6MPa (232 psi). Consult us for higher pressure.
Voltage		AC: 220V ± 10% or DC: 24V ± 10%
Nominal diameter		DN40 DN50 DN80 DN100 DN150 DN200
Classification		ExdIIBT4
Enclosure		IP 65
Main Valve Body		Carbon Steel Material. Consult us for other materials.

## ➤ PRINCIPLE OF OPERATION

FBD Series digital control valve consists of one normally-open (N.O.) solenoid valve, one normally-closed (N.C.) solenoid valve, three 3/8" ball valves and one main cutoff valve (see Figure 1).

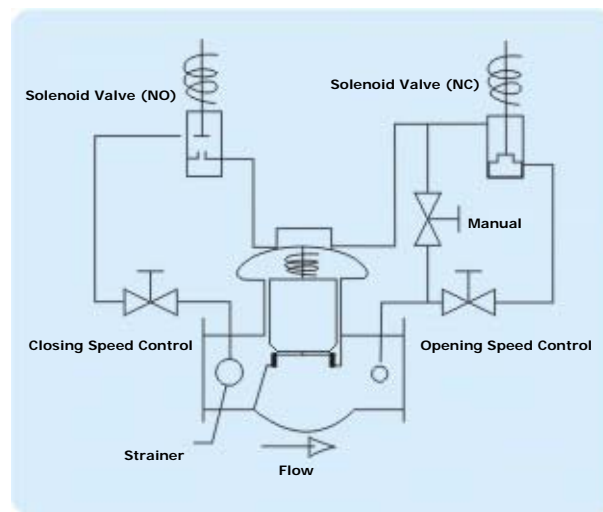

**Figure 1: Schematic Diagram**

The N.O. solenoid valve and N.C. solenoid valve located respectively in the upstream and downstream of the control loop. During the operation loading process in pipeline, when the digital control valve is required to be opened, the batch controller sends the opening signal to both solenoid valves. The N.O. solenoid coil is energized (valve shut), and the N.C. solenoid coil is also energized (valve turn on). At this time, the pathway, which passes from upstream to the upper chamber on diaphragm of main valve, is cutoff; and the pathway, which passes from upper chamber of piston of main valve to downstream, is opened. Thus the pressure in the lower (under the piston) is higher than the pressure of the upper (over the piston). The medium in the upper will pass through the N.C. solenoid valve's pathway and go into downstream pipeline. The main cutoff valve is opened.

When the valve is required to be closed, the batch controller sends the closing signal to both valves. The N.O. solenoid coil is de-energized (valve turn on), and the N.C. solenoid coil is also de-energized (valve shut). At this time, the pathway, which passes from upstream to the upper chamber of piston of main valve, is opened; and the pathway, which passes from the upper of piston of main valve to downstream, is cutoff. The high pressure medium in upstream passes through the N.O. solenoid valve and enters the upper chamber of piston of main valve. At this moment, the pressure in upper chamber is equal to the pressure in the lower. The spring force will make the main valve close.

During the opening or closing process of the main valve, the N.O. solenoid valve is energized (valve shut) and the N.C. solenoid valve is de-energized (valve shut). At this moment, both the upstream and downstream pathways are cutoff. Medium is pressured in upper chamber of piston of the main valve. The pressure difference between the upper and the lower will lock the valve at the open position to maintain the output flow-rate being constant. In case the upstream flow-rate is changed, the batch controller will send out corresponding control signals to both solenoid valves for adjusting the flow-rate to be the preset flow-rate, according to the feedback signal from the flow-meter.

Series FBDF digital control valve is equipped with two small ball valves in the circuit to be controlled, to be taken as response valve of the main valve. The ball valve in upstream circuit to be controlled is the close-adjusting valve and the ball valve in downstream circuit to be controlled is the open-adjusting valve. According to medium viscosity and actual pipeline pressure, the opening duration and closing duration of the main valve can be slightly adjusted by adjusting the opening degree of the two ball valves separately (closing degree of the two small valves cannot exceed 3/4 of its full range). In this way, the “water hammer” hazard can be avoided.



Series FBDF digital control valve is also equipped with one small ball valve in downstream circuit to be controlled, to be taken as manual control valve. When the power is cut-off or when the solenoid valve does not work, the main valve can be turn on or shut by manually operating this ball valve.

- **Piston Type Valves** are also available with the following nominal diameters at 1.6 MPa (232 psi) nominal pressure: -
  - DN 50 ( 2" )
  - DN 80 ( 3" )
  - DN 100 ( 4" )
- **NOTICE WHEN ORDERING:**
  - Describe its application
  - Specify its model or size
  - Specify working & maximum pressures
  - Specify product & maximum viscosity
  - Specify voltage
  - Other useful details or contact us

---

**TOTAL MEASUREMENT SOLUTIONS PROVIDER**

---



Serve Globally, Act Locally®

**GROWCO INTERNATIONAL**

*International Business Office :*

**271 Bukit Timah Road, #03-04 Balmoral Plaza, Singapore 259708**

**Tel : (65) 6842 1170**

**Email: [sales@growco.biz](mailto:sales@growco.biz)**

Distributed by:

**Fax : (65) 6842 1182**

**Web: [www.growco.biz](http://www.growco.biz)**

Growco International reserves the rights, without notice, to alter or improve the designs or specifications of the products described herein.

Printed in Singapore.