

The Growco LS-AR Series strainers are designed to filter out the solid impurity found in the pipeline to protect the downstream equipment such as flow meters, pumps, etc. The LS-AR series strainers have an air release head built-in at the upper part of the strainer as an integrated unit to save space and eliminate air / gas in the liquid to improve the performance of the downstream equipment such as flow meters, pumps, etc.

➤ **TYPICAL FEATURES OF LS-AR SERIES:**

- Stable and reliable operations.
- Straight through flow design.
- Simple structure and easy maintenance.
- Horizontal installation.



Photograph of Typical LS-AR Series Strainer with built-in air release head

➤ **PRINCIPLE OF OPERATIONS**

When the fluid flows through the inlet of the strainer, its pressure push the fluid into a basket strainer element (options for mesh sizes) to filter out the solid impurity before flowing to the outlet. The basket strainer element can be taken out for cleaning on a regular basis by following each customer's own maintenance practices or whenever necessary. The LS-AR series has an air release head built-in at the upper part of of the strainer. There is a special mechanism inside the air release head to allow air / gas to flow upwards for venting.

➤ **GENERAL SPECIFICATIONS**

Nominal Diameter (mm)*	40	50	80	100	150	200	250	300	350	400
Working Fluid *	Petroleum products such as diesel, gasoline, kerosene & crude oil; water or consult factory for other fluids									
Nominal Pressure Type*	1.6 ; 2.5 ; 4.0 ; 6.4 MPa									
Mesh No. Per Square Inch	40 (standard) Options : 20 /10									
Temperature range *	-30~+250°C									
Material of Construction *	Standard : Cast Steel Option : 304 SS & 316 SS									

* **Notes:** 1) Please provides the information during inquiry.

Typical LS-AR Approximate Dimensions & Data (with air release head):

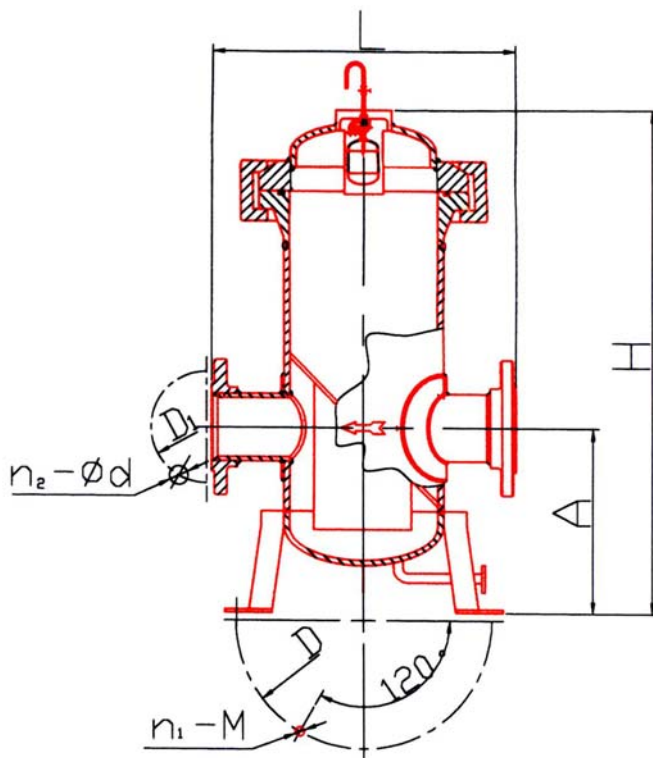

DN (mm)	Nominal Pressure MPa	Flange Dimensions			Base Dimensions			L	A	H	Mesh No.	Approx. Weight	
		D ₁	n ₂ .φd		M	D	n ₁ .vM					kg	
50	1.6, 2.5	125	4	18	M16	310	3	M16	320	237	705	20	40
	4.0	125	4	18	M16	310	3	M16				40	45
	6.4	135	4	23	M20	310	3	M16				40	55
80	1.6,2.5	160	8	18	M16	335	3	M16	420	260	830	20	65
	4.0	160	8	18	M16	335	3	M16				40	70
	6.4	170	8	23	M20	335	3	M16				40	75
100	1.6	180	8	18	M16	335	3	M20	520	315	1060	20	120
	2.5, 4.0	190	8	23	M20	335	3	M20				20	125
	6.4	200	8	25	M22	335	3	M20				40	140
150	1.6	240	8	23	M20	520	3	M20	720	500	1200	20	180
	2.5,4.0	250	8	25	M22	520	3	M20				20	188
	6.4	280	8	34	M30	520	3	M20				40	205
200	1.6	295	12	23	M20	634	3	M20	800	538	1530	10	480
	2.5	310	12	25	M22	634	3	M20				10	490
	4.0	320	12	30	M27	634	3	M20				20	505
	6.4	345	12	34	M30	634	3	M20				20	530
250	1.6	355	12	25	M22	658	3	M20	1000	580	1620	10	1300
	2.5	370	12	30	M27	658	3	M20				10	1330
	4.0	385	12	34	M30	658	3	M20				20	1375
300	1.6	410	12	25	M22	670	3	M22	1100	1070	2130	10	1750
	2.5	430	16	30	M27	670	3	M30				10	1800
	4.0	450	16	34	M30	670	3	M30				20	1880
350	1.6	470	16	25	M22	750	3	M30	1300	1100	2360	10	2000
	2.5	490	16	34	M30	750	3	M30				20	2150
400	1.6	525	16	30	M27	800	3	M30	1600	1100	2400	10	2480
	2.5	550	16	34	M30	800	3	M30				10	2580
500	1.6	650	20	34	M30	950	3	M30	2000	1150	2400	10	2600
	2.5	660	20	41	M36	950	3	M30				10	2720
600	1.6	770	20	41	M36	1100	3	M30	2200	1150	2500	10	2800
	2.5	770	20	41	M36	1100	3	M30				10	2950
700	1.6	840	24	41	M36	1350	3	M30	2500	1150	3000	10	3000
	2.5	875	24	48	M42	1350	3	M30				10	3200
800	1.6	950	24	41	M42	1500	4	M36	2700	1250	3000	10	3300
	2.5	990	24	48	M42	1500	4	M36				10	3500

Notes:

- 1) DN* - Nominal Diameter based on flange connection. Consult us when necessary.
- 2) All dimensions and weights shown in above table are approximate for reference only.

CAUTIONS FOR THE INSTALLATION:

- ❑ Welding slug, foreign particles, etc. in the pipe must be cleared up before the Strainer is installed.
- ❑ Install the strainer correctly (e.g. Horizontally).
- ❑ The strainer must be installed at the upstream of the Flow meter.
- ❑ Please also follow any required local standard recommendations of pipelines installations to ensure compliance to local safety requirements.

➤ NOTICE WHEN ORDERING:

- Describe its application.
- Specify its model/series or size.
- Specify working & maximum pressures.
- Specify product & maximum viscosity.
- Specify horizontal installation.
- Other useful details or contact us.

TOTAL MEASUREMENT SOLUTIONS PROVIDER



Distributed by:

GROWCO INTERNATIONAL

International Business Office :

271 Bukit Timah Road, #03-04 Balmoral Plaza, Singapore 259708

Tel : (65) 6842 1170

Fax : (65) 6842 1182

Email: sales@growco.biz

Web: www.growco.biz

Growco International reserves the rights, without notice, to alter or improve the designs or specifications of the products described herein.

Printed in Singapore.