

The leak sensor is specially designed for double-wall tanks, can detect and identify water and fuel in the interlayer.

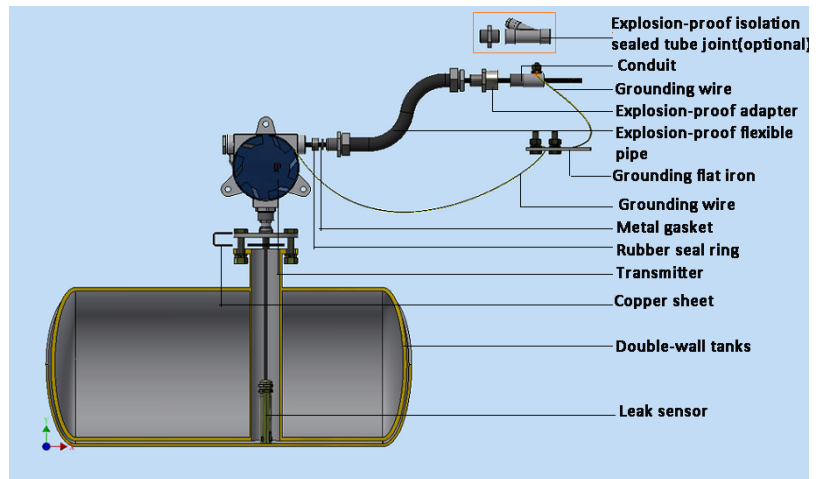

### Features :

- Compact and beautiful appearance, easy to maintain.
- Explosion-proof design, safe and reliable.
- High sensitivity and strong anti-interference.
- One same bus can be connected to 8 leak sensors.
- Can identify fuel and water; then give corresponding alarm.
- Leak sensor fault alarm function.
- LED alarm prompt function.

Connect with leak alarm controller by RS485 bus communication, communication distance is up to 600 meters.

## Technical parameters :

- Working temperature:  $-40^{\circ}\text{C}\sim+60^{\circ}\text{C}$
- Relative humidity: 30%~90%
- Power supply:  $\text{DC}12\text{V}\pm 0.5\text{V}$  (by safety barrier)
- Operating current:  $<35\text{mA}$
- Response time:  $<2\text{S}$
- Alarm type: LED alarm
- Ex-mark: Ex ia IIC T4 Ga
- Intrinsic safety parameter:

Power port:  $U_i=12.6\text{VDC}$ ,  $I_i=291\text{mA}$ ,  $P_i=0.92\text{W}$ ,  $C_i=1.6\mu\text{F}$ ,  $L_i=0\text{mH}$ ;

Signal port:  $U_i=7.14\text{VDC}$ ,  $I_i=147\text{mA}$ ,  $P_i=0.26\text{W}$ ,  $C_i=0.11\mu\text{F}$ ,  $L_i=0\text{mH}$ .

## NOTES WHEN ORDERING:

- Specify its model.
- Specify supply voltage.
- Other useful details or contact us.

---

**TOTAL MEASUREMENT SOLUTIONS PROVIDER**  
**Member of Singapore Manufacturing Federation(Since 1932)**

---



Distributed by:

### GROWCO INTERNATIONAL

*International Business Office :*

**271 Bukit Timah Road, #03-04 Balmoral Plaza, Singapore 259708**

**Tel : (65) 6842 1170**

**Fax : (65) 6842 1182**

**Email: [sales@growco.biz](mailto:sales@growco.biz)**

**Web: [www.growco.biz](http://www.growco.biz)**

Growco International reserves the rights, without notice, to alter or improve the designs or specifications of the products described herein.

Origin of Singapore.